

Type 056260

Armaturen für Schiffbau und Industrie
Valves for shipbuilding and industry



**Flanschenschieber PN 16
aus Rotguss
mit nichtsteigender Spindel
und eingeschraubtem Oberteil
Flansche nach DIN PN 16**

**flanged gate valves PN 16
bronze
with non rising stem
and screwed-in bonnet
flanges acc. to DIN PN 16**

Materialspezifikation:

Gehäuse:	CuSn5Zn5Pb5-C	CC491K
Oberteil:	CuZn39Pb2	CW612N
Keil:	CuSn5Zn5Pb5-C	CC491K
Spindel:	CuZn39Pb2	CW612N
Handrad:	Zinkguss	-

material specification:

body:	CuSn5Zn5Pb5-C	CC491K
bonnet:	CuZn39Pb2	CW612N
wedge:	CuSn5Zn5Pb5-C	CC491K
stem:	CuZn39Pb2	CW612N
handwheel	zinc-casting	-

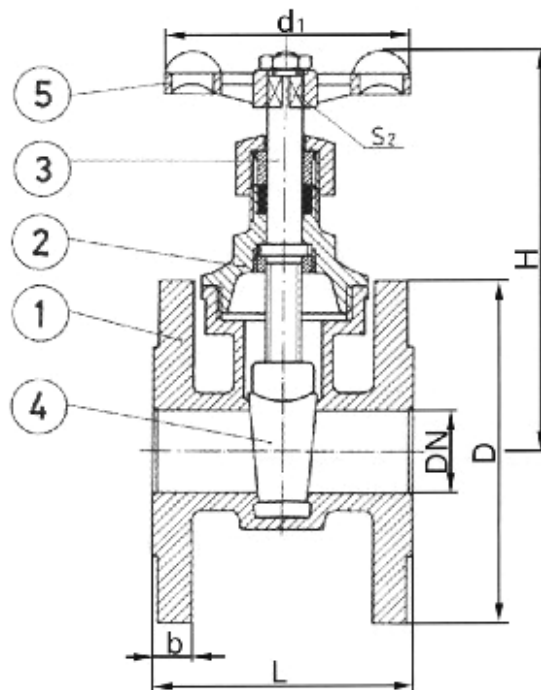

Type 056260

NW/DN	L	H	D	PCD	Holes	d1	b	S2	KG
020	75	105	105	75	4 x 14	70	12	7	1,8
025	80	115	115	85	4 x 14	70	12	8	2,3
032	90	130	140	100	4 x 18	80	14	9	3,6
040	100	150	150	110	4 x 18	90	14	9	4,6
050	110	180	165	125	4 x 18	110	16	11	6,4
065	130	220	185	145	4 x 18	150	16	12	9,4
080	150	250	200	160	8 x 18	160	18	13	12,1